

**Trhací nýt se zapaštěnou hlavou**  
 Hlava ALUMINIUM 3,5% Mg  
 TRN OCEL/Zinek Bílý

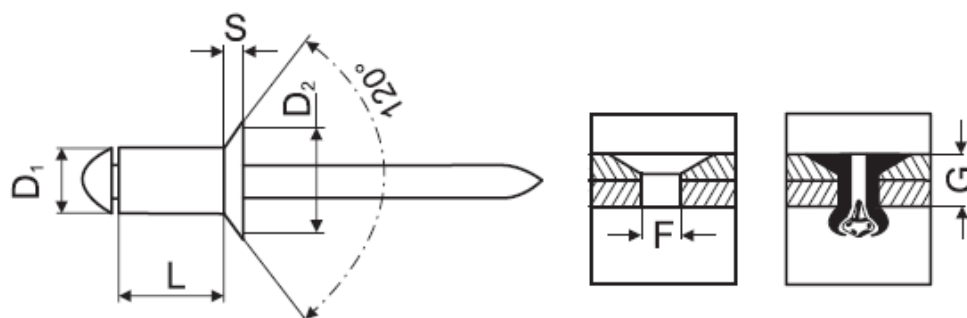

DIN: 7337B  
 ČSN: 02 2391  
 ISO:



D1: 2,4mm D2: 6,0mm	D1xL	G Svěrná tl.	Pevnost v tahu	Pevnost na stříh	Kód Fastek
S: 0,9mm F: 2,5mm	2,4x6	1,5-4,0	355N	315N	9NZS2406AS
	2,4x8	4,0-6,0			9NZS2408AS
	2,4x10	6,0-8,0			9NZS2410AS

D1: 3,0mm D2: 6,0mm	D1xL	G Svěrná tl.	Pevnost v tahu	Pevnost na stříh	Kód Fastek
S: 0,9mm F: 3,1mm	3,0x6	1,5-3,5	810N	315N	9NZS3006AS
	3,0x8	3,5-5,5			9NZS3008AS
	3,0x10	5,5-7,0			9NZS3010AS
	3,0x12	7,0-9,0			9NZS3012AS
	3,0x14	9,0-12,0			9NZS3014AS

D1: 3,2mm D2: 6,0mm	D1xL	G Svěrná tl.	Pevnost v tahu	Pevnost na stříh	Kód Fastek
S: 0,9mm F: 3,3mm	3,2x6	1,5-3,5	980N	760N	9NZS3206AS
	3,2x8	3,5-5,0			9NZS3208AS
	3,2x10	5,0-7,0			9NZS3210AS
	3,2x12	7,0-9,0			9NZS3212AS
	3,2x14	9,0-10,5			9NZS3214AS
	3,2x16	10,5-13,0			9NZS3216AS

<b>D1: 4,0mm D2: 7,5mm</b>	<b>D1xL</b>	<b>G Svěrná tl.</b>	<b>Pevnost v tahu</b>	<b>Pevnost na střih</b>	<b>Kód Fastek</b>
<b>S: 1,0mm F: 4,1mm</b>	4,0x6	1,5-3,0	1600N	1200N	9NZS4006AS
	4,0x8	3,0-5,0			9NZS4008AS
	4,0x10	5,0-6,5			9NZS4010AS
	4,0x12	6,5-8,6			9NZS4012AS
	4,0x14	8,5-10,5			9NZS4014AS
	4,0x16	10,5-12,5			9NZS4016AS
	4,0x18	12,5-14,5			9NZS4018AS
	4,0x20	14,5-16,5			9NZS4020AS

<b>D1: 4,8mm D2: 9,0mm</b>	<b>D1xL</b>	<b>G Svěrná tl.</b>	<b>Pevnost v tahu</b>	<b>Pevnost na střih</b>	<b>Kód Fastek</b>
<b>S: 1,2mm F: 4,9mm</b>	4,8x6	1,0-3,5	2230N	1690N	9NZS4806AS
	4,8x8	2,0-4,5			9NZS4808AS
	4,8x10	4,5-6,0			9NZS4810AS
	4,8x12	6,0-8,0			9NZS4812AS
	4,8x14	8,0-10,0			9NZS4814AS
	4,8x16	10,0-12,0			9NZS4816AS
	4,8x18	12,0-14,0			9NZS4818AS
	4,8x20	14,0-16,0			9NZS4820AS
	4,8x25	16,0-21,0			9NZS4825AS
	4,8x30	21,0-25,0			9NZS4830AS
	4,8x35	25,0-30,0			9NZS4835AS

<b>D1: 5,0mm D2: 9,0mm</b>	<b>D1xL</b>	<b>G Svěrná tl.</b>	<b>Pevnost v tahu</b>	<b>Pevnost na střih</b>	<b>Kód Fastek</b>
<b>S: 1,3mm F: 5,1mm</b>	5,0x8	2,5-4,5	2500N	2000N	9NZS5008AS
	5,0x10	4,5-6,0			9NZS5010AS
	5,0x12	6,0-8,0			9NZS5012AS
	5,0x14	8,0-10,0			9NZS5014AS
	5,0x16	10,0-12,0			9NZS5016AS
	5,0x18	12,0-14,0			9NZS5018AS
	5,0x20	14,0-17,0			9NZS5020AS
	5,0x25	17,0-21,0			9NZS5025AS
	5,0x30	21,0-25,0			9NZS5030AS